

1.5ml Strip Tube (#60615/60715)

1. Description

1.5ml Strip Tube, provided as strips of six microcentrifuge tubes physically connected in a row, is ideal for any large scale experiments. The strips can be cut into individual tubes, and are universally applicable to centrifugation*.

※ 1.5ml strip tube may restrictedly be compatible to rotors, depending on the types of rotor being used for centrifugation. Compatibility test, before proceeding experiment, is highly recommended. (Compatible to most 24-, 30-hole rotors, and few 18-hole rotors)

2. Features

- ❖ Smooth opening and tight closing
- ❖ Imprinted external graduations with marking area
- ❖ Central part in cap enough to be penetrated by syringe needle
- ❖ Autoclavable

3. Functional Test

Cytotoxicity : Passed
 Non-Pyrogenic : Passed
 RNase/DNase free : Passed
 DNA free : Passed

4. Product Range

Cat. No.	Material	Color	Total Volume (ml)	RCF rating	Sterile	Packaging
60615	PP	Clear	1.50	30,000 x g	-	80 / 800
60715	PP	Clear	1.50	30,000 x g	+	40 / 800

5. Certification

SPL Life Sciences hereby certifies that the product identified above, inspected to be in compliance with product quality specification and requirements as documented in our ISO 9001:2008 Quality Management System (K-QA-Q031478) in Korea.

6. Product Photographs



SPL-TDS-1.5ST

For Research Use Only. Not intended for use in diagnostic or therapeutic procedures.
 © SPL Life Sciences Co., Ltd., Version 2, July 19th, 2016

7. Specifications & Technical Drawing

- Specifications

Dimensions		Material (Resin)	Packaging	
			60615	60715
Diameter:	10.8 mm	Polypropylene (PP)	▪ Pieces/Sleeve: 80	▪ Pieces/Sleeve: 40
Height:	39.0 mm		▪ Pieces/Case: 800	▪ Pieces/Case: 800

- Technical Drawing

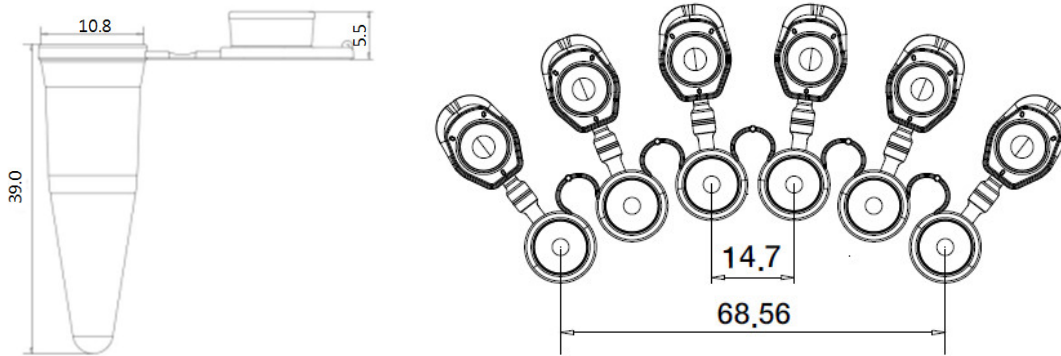

-Specifications when combined with 1.5ml Strip Tube Rack (#61024), Size may vary when detached from the rack

www.spllifesciences.com

For technical assistance, contact SPL R&D Center at:
 Tel: +82-31-533-4800; Fax: +82-31-533-1430; e-mail: spl@ispl.co.kr
 To place an order, contact your local distributor or
 Tel: +82-31-533-4800; Fax: +82-31-533-1430; e-mail: business@ispl.co.kr

SPL-TDS-1.5ST

For Research Use Only. Not intended for use in diagnostic or therapeutic procedures.
 © SPL Life Sciences Co., Ltd., Version 2, July 19th, 2016